



DENSO 
INVENTOR OF THE QR CODE®

[BHT-1200 Series]



Ergonomic design—easy to hold and operate



Fast wireless communication; supports IEEE802.11b/g/n



Super high-speed scanning increases work efficiency



Large, easy-to-view 3.5-inch HVGA color display



Robust, highly durable construction

1-D and 2-D models



HIGH-PERFORMANCE GLOBAL MODEL INCREASES EFFICIENCY

Easy to operate—The flexibility of a PDA, with the power of a terminal



Easy to operate with only one hand, or even with just your thumb.

- ▣ Ergonomic key arrangement enables one-hand operation.



Easy to hold

- ▣ About the same width as a smartphone (57 mm); shaped to fit easily in your hand.



Secure grip

- ▣ Stable one-hand operation with built-in hand strap.



12 function keys

- ▣ One-key access for up to 12 frequently used functions.
- ▣ Backlight allows use in dark environments.



Large screen lets you quickly see information at a glance

- ▣ High-precision, 3.5-inch HVGA color display clearly shows even small-sized characters.



SCANNING PERFORMANCE

Superfast scanning. Scans reliably even at a distance.



1-D model

- ▣ 400 scans per second.
- ▣ Reads even complicated codes at high speed.
- ▣ Reading speed is three times faster than conventional laser scanners.
- ▣ Reads even scratched or damaged codes, so you can work fast without interruption.



1-D model

- ▣ Read codes at a distance without having to change position.
- ▣ Read codes from close up, or as far away as 25 feet or more.
- ▣ Easy to scan items on all shelves, from top to bottom.

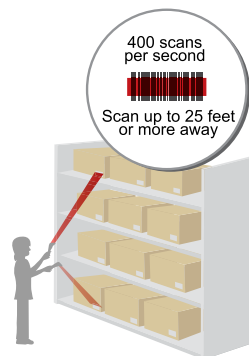

2-D model

- ▣ Laser indicates scanning range and center of focus.
- ▣ Patented scanner rangefinder enables fast scanning. *Patent No.3562395



Scanning range*

Center of scanning field

GLOBAL SUPPORT SYSTEM

Experience DENSO quality and service, worldwide



Comprehensive support system available in more than 40 countries throughout the world.

DENSO Group operates globally, providing prompt support with a full range of services, from sales to maintenance. Language options allow you to change the language being displayed.

Large installed base

USA, Japan, EU (27 countries), Canada, Taiwan, Korea, Australia, New Zealand, Thailand, Malaysia, Indonesia, Philippines, Hong Kong, China, Russia, Brazil

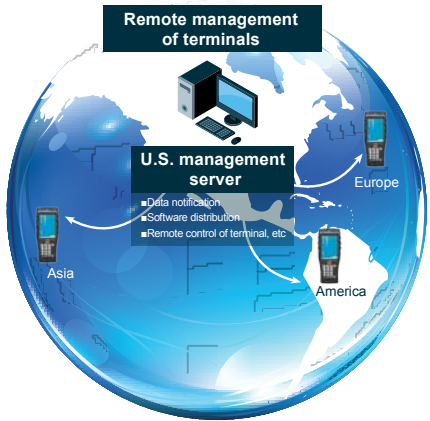

MobiControl worldwide terminal management

Supports an integrated management tool with the world's largest market share. Dramatically reduces the cost and effort required for application support.

The BHT-1200 supports MobiControl® integrated management tool for terminals**. No matter where your terminals are used throughout the world, they are managed by the MobiControl server, resulting in a reduction in the cost and effort required to run them and ensuring that they continue to operate seamlessly.

- ☑ **Synchronize management server and terminal**
Collect data from each terminal and distribute data stored on the server.
- ☑ **Easy to install and update application software**
Automatic software updates.
- ☑ **Identify terminal faults when errors occur**
Analyze terminal program to find the cause of the failure.
- ☑ **Enhanced security protects against information theft**
Embedded security functions protect in case of terminal loss as well as against server attack or information theft. Automatic software updates.

* MobiControl is a registered trademark of Soti, Inc.
** Separate contract required to use MobiControl.

WIRELESS AND SECURITY

The stability and speed required for business use



Fast wireless communication. Avoid delays caused by network congestion.

- ☑ Supports IEEE802.11b/g/n, for reliable high-speed wireless communication.
- ☑ Reconnect to the wireless network in just one second, using DENSO's proprietary software.



Prevent unauthorized access.

- ☑ Highly reliable WPA/WPA2 (as well as WEP) network security.

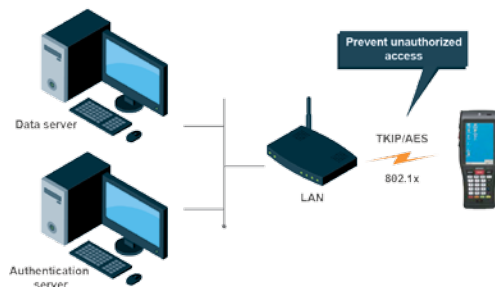

CAMERA

5.0-megapixel camera



- ☑ Take photos of defective products while scanning.
- ☑ Dual-function product features 5.0-megapixel camera.
- ☑ Convenient autofocus and built-in flash.



DATA BACKUP



- ☑ Back up RAM data to MicroSDHC.



- ☑ High-capacity, 2 GB flash ROM.

DURABILITY



- ☑ Usable in cold storage and even outdoors in hot summer weather.
- ☑ Operating temperature -4 to 122 °F (-20 to 50 °C)



- ☑ Cylindrical jacket structure protects PCB (main board) from impact, dust and water.

BHT-1200 SPECIFICATIONS

		1-D model	2-D model	
		Built-in microphone and receiver		
Type		BHT-1261BWB-CE	BHT-1261QWB-CE	
OS		Windows® Embedded CE 6.0 R3		
CPU		ARM Coretex-A8 800 MHz		
Memory	RAM	Mobile DDR 512 MB		
	ROM	2.0 GB		
Display	Number of pixels ¹	320 x 480 (3.5" HVGA) / 240 x 320 (3.5" QVGA)		
	Display	Liquid crystal dot matrix (color)		
	Backlight	White LED		
Scanner	Scanning system	Advanced Scan Plus™ (CCD)	Area sensor	
	Readable codes	1-D codes	EAN-13/-8(UAN-13/-8), UPC-A-E, UPC/EAN (add-on embedded), Interleaved 2 of 5, Standard 2 of 5, Codabar (NW-7), Code 39, Code 93, Code 128, GS1-128 (EAN-128), MSI, GS1 DataBar (RSS)	EAN-13/-8(UAN-13/-8), UPC-A-E, UPC/EAN (add-on embedded), Interleaved 2 of 5, Codabar (NW-7), Code 39, Code 93, Code 128, GS1-128 (EAN-128), GS1 DataBar (RSS)
		2-D codes	-	QR Code, micro QR Code, SQRC, iQR, PDF417, micro PDF417, MaxiCode, Data Matrix (ECC 200), Aztec, GS1 DataBar Composite (EAN.UCC Composite)
	Minimum resolution	1-D codes	0.125 mm	
		2-D codes	-	0.167 mm
	Scanning guide	CCD illumination		Laser guide pattern
	Scan confirmation	LED (three colors: red, green, blue), speaker, vibration		
Keyboard	Number of keys	30 (excluding power key) plus 3 trigger keys		
Network	Wireless I/F	Standard	IEEE802.11b/g/n	
		Frequency	2.4 GHz	
		Network range ²	Indoor: approx. 150 m; outdoor: approx. 300 m	
		Transmission Speed ²	IEEE802.11b: 11/5.5/2/1 Mbps; IEEE802.11g: 54/48/36/24/18/12/9/6 Mbps; IEEE802.11n: 65/58.5/52/39/26/19.5/13/6.5 Mbps	
	Security	WEP40, 128, WPA-PSK (TKIP, AES), WPA2-PSK (TKIP, AES), WPA-1x (TKIP, AES/EAP-TLS, PEAP), WPA2-1x (TKIP, AES/EAP-TLS, PEAP), 802.1x (EAP-TLS, PEAP)		
	Bluetooth	Bluetooth Ver 2.0, EDR Class 2		
Cradle I/F	RS-232C/USB client			
Card slot	MicroSDHC			
Camera	5.0 megapixels, auto-focusing			
Power	Main battery	Lithium-ion		
	Operating time ³	Standard battery: approx. 23 hours High-capacity battery: approx. 34 hours	Standard battery: approx. 22 hours High-capacity battery: approx. 33 hours	
Additional functionality	VOIP, speaker, vibration alert, battery-voltage indicator, key backlight, G-sensor, microphone, clock			
Environmental requirements	Operating temperature	-4 to 122°F (-20 to 50 °C) ⁴		
	Protection level	IP54		
	Drop resistance ⁵	Drop onto concrete floor more than 1,000 times from 0.2 m and 30 times from 1.5 m (5 times on each of 6 sides)		
Weight (incl. battery, stylus pen, hand strap) ⁶	Approx. 330 g		Approx. 340 g	

DIMENSIONS

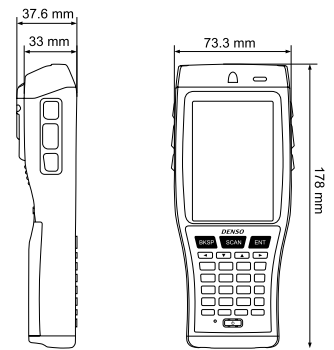

INCLUDED ACCESSORIES

- Hand strap
- Stylus pen
- Operation guide
-  User manual

Battery and battery cover not included.

SOFTWARE

-  Software Development Kit (SDK) for BHT Windows® CE¹
 - Keyboard interface software [kbifCE]²
1. Can be downloaded at www.denso-adc.com free of charge by customers who have purchased a Windows-version BHT.
 2. Pre-installed on BHT.

 Items with this symbol are available from www.denso-adc.com free of charge.

1. LCD manufactured with high-precision technology. Number of available pixels is 99.99% (max. 0.01% of pixels may be missing or turned off).
2. Transmission range and speed are theoretical values and may vary depending on operating environment.
3. At a scanning:wireless transmission:screen update:standby ratio of 1:1:20, with wireless on standby (power-save on) and LCD backlight low. Operating time given is for room temperature and may vary depending on environmental conditions.
4. Rises from 0 to 40 °C (32 to 104 °F) while charging.
5. Test value only (not guaranteed).
6. When using standard battery.

OPTIONAL ACCESSORIES (sold separately)

Transmission unit (cradle) for data communication between BHT and higher-level devices

- CU-1233 (RS-232C/USB communication, main-unit charging, reserve-battery charging)
- CU-1211 (Ethernet communication, main-unit charging, reserve-battery charging)



	CU-1233	CU-1211
Communication mode	RS-232/USB 2.0	Ethernet (100BASE-TX)
Charging time (main unit)	Standard battery: approx. 3 hrs.; high-capacity battery: approx. 4.5 hrs.	
Reserve charging	Standard battery: approx. 3 hrs.; high-capacity battery: approx. 4.5 hrs.	
Dimensions (mm)	133 (D) x 97 (W) x 101 (H)	
Power supply	AC adapter (AD3-1012/3000-2)	



BHT-1200 Web page

Direct cable

- Connects BHT to higher-level devices
- RS-232C USB

Batteries

- BT-110LA BT-120LA-C
- BT-110L BT-120L-C

Cases and shoulder belt

- SCBHT-1100/1200
- SCBHT-1200Q
- WHBHT-1200
- SBBHT-700

DENSO 
INVENTOR OF THE QR CODE®

[DENSO ADC]

3900 Via Oro Ave.
Long Beach, CA. 90810
Phone + (888) MY DENSO
+ (888) 693 3676
Fax + (310) 835 8724
denso-adc@denso-diam.com
www.denso-adc.com

Legacy Technology Services

We Rent & Sell All Types Of Barcode Equipment

Call now to talk to an expert

866-271-9891

www.LegacyGlobal.com

Some brands we carry



MOTOROLA

Intermec

DATALOGIC™

Honeywell

EQUINOX
PAYMENTS

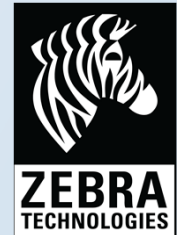

About us

- Legacy Technology Services is a leading nationwide provider of mobile computing, barcode, printers and point of sale equipment and services.
- For over a decade, thousands of clients across North America have trusted us to provide equipment from leading manufacturers backed by the services to support them.

Latest Hardware from top manufacturers

- Legacy handles virtually every major manufacturer of mobile computing, barcoding and point of sale equipment.

Expert Repair and Maintenance services

- Legacy is one of the best repair facilities in North America

Discontinued product sourcing

- They don't make it anymore? Our inventory also includes manufacturer close-outs and discontinued equipment to support our clients legacy infrastructure.

Trade-in and Disposal services

- That old equipment laying around your facility may still have some value. Legacy routinely purchases equipment from our clients around the globe.
 - Data destruction
 - Hardware disposal
 - Auditing services

Dedicated client account team

- Dedicated, highly trained account managers are here to answer all your questions and provide top notch service.

Equipment rental services

- Sometimes renting is a better solution, Legacy's huge rental inventory provides the equipment you need for temporary needs and projects.



Legacy, Inc.

160 West Road,
Ellington, CT 06029

Toll Free: 866-271-9891

Fax: 888-522-4684